



Description

The DIN-HUB is a DIN rail-mounted Cresnet hub designed to facilitate the configuration of large Cresnet networks. DIN rail mounting enables modular installation alongside Crestron® DIN Rail lighting and automation control modules and other third-party DIN rail mountable devices.

DIN-HUB Specifications

SPECIFICATION	DETAILS
Power Requirements	
Cresnet Power Usage	0.6 W (0.03 A @ 24 Vdc)
Maximum Load per Segment	75 W (3.13 A @ 24 Vdc)
Environmental	
Temperature	32° to 104 °F (0° to 40 °C)
Humidity	10% to 90% RH (noncondensing)
Heat Dissipation	2 Btu/h

Additional Resources

Visit the product page on the Crestron website (www.crestron.com) for additional information and the latest firmware updates. Use a QR reader application on your mobile device to scan the QR image.



Installation

CAUTION: This equipment is for indoor use only. Mount in a well-ventilated area. The ambient temperature must be 32° to 104 °F (0° to 40 °C). The relative humidity must be 10% – 90% (noncondensing).

NOTE: Observe the following points:

- Install and use this product in accordance with appropriate electrical codes and regulations.
- A licensed electrician should install this product.

NOTE: Before using the DIN-HUB, ensure the device is using the latest firmware. Check for the latest firmware for the DIN-HUB at www.crestron.com/firmware. Load the firmware onto the device using Crestron Toolbox™ software.

The DIN-HUB is designed for installation on a DIN rail. Refer to the following diagram when installing.

1. Place the top of the DIN-HUB's rail mount over the top of the DIN rail.
2. Tilt the bottom of the DIN-HUB toward the DIN rail until it snaps into place.

NOTE: When mounting DIN rail products, use a flat-head screw driver to pull the DIN rail release tab while snapping the device onto the DIN rail.

To remove the DIN-HUB from the DIN rail, use a small, flat object (i.e., a flat-head screwdriver) to pull the DIN rail release tab, and tilt the bottom of the DIN-HUB away from the DIN rail.

NOTE: Certain third-party DIN cabinets provide space for an informational label between each DIN rail row. Crestron's Engraver software (version 4.0 or later) can generate appropriate labels for all Crestron DIN rail products.

Installing the DIN-HUB

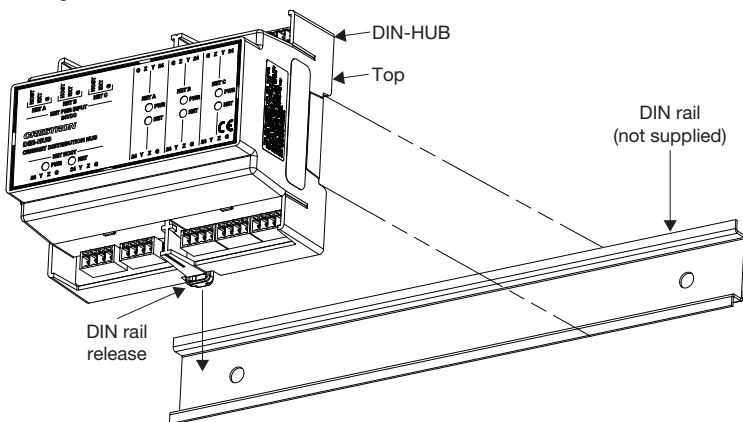

Hardware Hookup

Make the necessary connections as called out in the illustration below. Apply power after all connections have been made. When making connections to the DIN-HUB, use a Crestron power supply.

CAUTION: Insufficient power can lead to unpredictable results or damage to the equipment. Please use the Crestron Power Calculator to help calculate how much power is needed for the system (www.crestron.com/calculators).

NOTE: Use Crestron Certified Wire. Cresnet HP wire cannot be used.

NOTE: When making connections, strip the ends of the wires approximately 7/16 in (11 mm). Use care to avoid nicking the conductors. Tighten the connector to 5 in-lb (0.5 to 0.6 N-m). The wire gauge should be 14 to 26 AWG.

Hardware Connections for the DIN-HUB

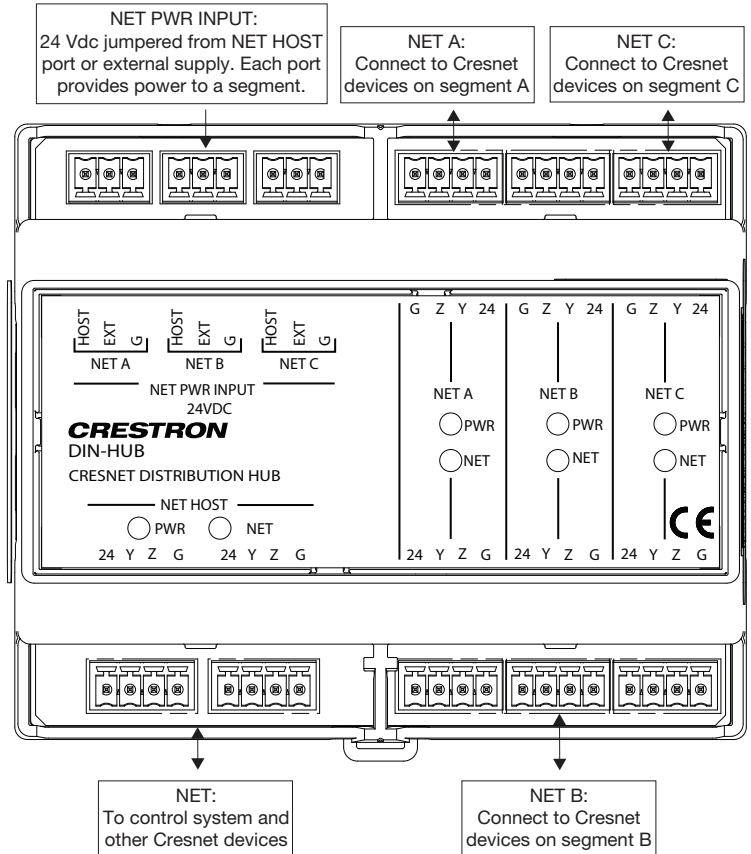

Power can be supplied from a DIN rail power supply or other Cresnet power supply connected to the NET HOST port.

NOTE: The DIN-HUB can only be powered by the NET HOST port. Power cannot be supplied from network devices that are connected to any of the segments.

Hub segments can be powered internally or from an external power supply. To power a segment internally, install a jumper from the HOST pin to the EXT pin on the segment's NET PWR INPUT port.

Powering a Hub Segment Internally (Segment A Shown)

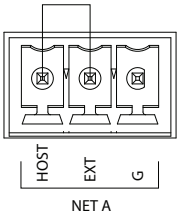

To power a segment externally, connect the external power supply to the EXT and G pins on the segment's NET PWR INPUT port.

Powering a Hub Segment Externally (Segment A Shown)

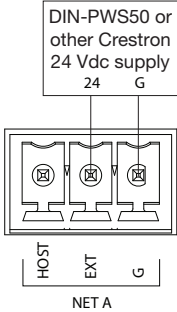

Troubleshooting

The following table provides corrective actions for possible trouble situations. If further assistance is required, please contact a Crestron customer service representative.

DIN-HUB Troubleshooting

TROUBLE	POSSIBLE CAUSE(S)	CORRECTIVE ACTION
The NET HOST PWR LEDs do not light.	The DIN-HUB is not receiving power.	Determine that the NET HOST port on the DIN-HUB is properly connected to a Cresnet power supply.
The segment's NET LED does not light.	The segment is improperly wired.	Verify wiring connections: proper connector is used, cable is intact, and connections are secure.
	One or more devices attached to the segment are not properly identified in SIMPL Windows.	Use Crestron Toolbox to verify that the SIMPL Windows program recognizes all of the devices.
	Another segment is improperly wired.	Remove all segment connections except for the segment attached to the control system and the segment for which the LED is not lit.
The segment's PWR LED does not light.	The wiring at the NET PWR INPUT port is incorrect.	Verify that the NET PWR INPUT port is wired correctly for internal or external power.
	There is insufficient power.	Verify that sufficient power is available. If necessary, connect the NET PWR INPUT port to an external power supply.
The network is not working, and only one LED lights.	There is a wiring problem.	Disconnect the segment that resulted in the lit LED, and correct the wiring.

As of the date of manufacture, the device has been tested and found to comply with specifications for CE marking.



Federal Communications Commission (FCC) Compliance Statement

This device complies with part 15 of the FCC Rules. Operation is subject to the following conditions: (1) This device may not cause harmful interference and (2) this device must accept any interference received, including interference that may cause undesired operation.

CAUTION: Changes or modifications not expressly approved by the manufacturer responsible for compliance could void the user's authority to operate the equipment.

NOTE: This equipment has been tested and found to comply with the limits for a Class B digital device, pursuant to part 15 of the FCC Rules. These limits are designed to provide reasonable protection against harmful interference in a residential installation. This equipment generates, uses and can radiate radio frequency energy and, if not installed and used in accordance with the instructions, may cause harmful interference to radio communications. However, there is no guarantee that interference will not occur in a particular installation. If this equipment does cause harmful interference to radio or television reception, which can be determined by turning the equipment off and on, the user is encouraged to try to correct the interference by one or more of the following measures:

- Reorient or relocate the receiving antenna.
- Increase the separation between the equipment and receiver.
- Connect the equipment into an outlet on a circuit different from that to which the receiver is connected.
- Consult the dealer or an experienced radio/TV technician for help.

The product warranty can be found at www.crestron.com/warranty.

The specific patents that cover Crestron products are listed at patents.crestron.com.

Certain Crestron products contain open source software. For specific information, please visit www.crestron.com/opensource.

Crestron, the Crestron logo, Cresnet, and Crestron Toolbox are either trademarks or registered trademarks of Crestron Electronics, Inc. in the United States and/or other countries. Other trademarks, registered trademarks, and trade names may be used in this document to refer to either the entities claiming the marks and names or their products. Crestron disclaims any proprietary interest in the marks and names of others. Crestron is not responsible for errors in typography or photography.

This document was written by the Technical Publications department at Crestron.

©2016 Crestron Electronics, Inc.

Crestron Electronics, Inc.
15 Volvo Drive Rockleigh, NJ 07647
Tel: 888.CRESTRON
Fax: 201.767.7576
www.crestron.com

Installation Guide - DOC. 6671B
(2020753)

10.16

Specifications subject to change without notice.